

09

DODGE CHARGER



**COMBINE LEGENDARY HEMI[®] POWER, FUEL-SAVING MDS
TECHNOLOGY, AND SPORT CAR HANDLING, AND YOU
END UP WITH A DRIVING EXPERIENCE LIKE NO OTHER.
THIS IS THE 2009 DODGE CHARGER.**



MODERN MUSCLE THAT'S BEST-IN-CLASS. Charger R/T is powered by the brilliantly redesigned 5.7-liter VVT (Variable Valve Timing) HEMI® V8 engine with a Multi-Displacement System (MDS) for added fuel economy^[1] and a 5-speed AutoStick® transmission. Besides offering best-in-class^[2] 368 horsepower and 391 lb-ft of torque, Charger gives you a smooth ride that grips the road with a standard Electronic Stability Program (ESP)^[3] with all-speed traction control and brake assist and a performance four-wheel antilock brake system (ABS). Charger SRT8® features a 6.1-liter SRT® HEMI V8 that pushes the envelope with a whopping 425 horsepower and 420 lb-ft of torque, taking you from 0-60 in the five-second range — with handling dynamics that blend power with precision. Find out more at www.dodge.com/charger ^[1]16/25 city/highway mpg with MDS. Results depend on driving habits and conditions. ^[2]Based on 2008 *Ward's* Automotive segmentation. ^[3]No system, no matter how sophisticated, can repeal the laws of physics or overcome careless driving actions. Performance is limited by available traction which snow, ice and other conditions can affect. When the ESP warning lamp flashes, the driver needs to use less throttle and adapt speed and driving behavior to prevailing road conditions. Always drive carefully, consistent with conditions. Always wear your seat belt.

Charger SRT8 in Brilliant Black Crystal Pearl and Charger R/T in Deep Water Blue Pearl.

BEST-IN-CLASS^[1] 368 HP

AND 391 LB-FT OF TORQUE.



Charger R/T in Dark Titanium Metallic.

EXTERIOR STYLE

SIGNATURE CROSSHAIR GRILLE. Just below the long, wide hood, Charger's front end is dominated by the signature Dodge grille, with aggressive, even intimidating headlamps.

SLOPING FASTBACK ROOFLINE. Charger's unique styling features distinctive side glass and a sloping fastback roofline, with the beltline kicking up over the rear wheel arches, creating a muscular shoulder over the wheel well.

18-INCH WHEELS. 18-inch ultra-brite aluminum wheels on R/T are pushed to the corners for a strong stance, reducing front and rear overhangs to enhance vehicle stability and ride quality.

DUAL BRIGHT EXHAUST TIPS. Charger makes a strong impression, even when disappearing down the road, with an aerodynamic rear deck lid ending in a raised lip to reduce lift, and dual bright exhaust tips on R/T and SRT8[®] that lend more than a hint of its formidable power. For more style points, visit dodge.com/charger ^[1]Based on 2008 *Ward's* Automotive segmentation with 5.7L HEMI[®] VVT V8.



HEMISTRY. It began as code name Eagle. Chrysler engineers took the ingeniously powerful and masterfully efficient 5.7-liter HEMI® V8 power plant with Multi-Displacement Engine System (MDS) and outfitted it with Variable Valve Timing (VVT), which improves engine breathing for better efficiency and power. Building on the quality, reliability, and durability of the HEMI engine, the engineers also increased compression ratios and improved piston and valve spring design, as well as oil pump capacity. The result was an upgrade in mileage and power, especially at lower engine speeds.



6.1L SRT® HEMI V8. The high-performance 6.1-liter SRT HEMI V8 pumps out an awesome 425 horsepower and 420 lb-ft of torque. It was developed by increasing the bore of each cylinder, increasing compression ratio, redesigning the intake and exhaust systems for better airflow, and increasing engine speed.



3.5L HIGH OUTPUT SOHC V6. The formidable 3.5-liter High Output V6 engine, with its refined dual-tuned intake manifold, brings 250 horsepower and 250 lb-ft of torque to the table. Platinum-tip spark plugs allow for 100,000-mile scheduled tune-up intervals.



2.7L DOHC V6. The 2.7-liter V6 on Charger SE pumps out 178 horsepower and 190 lb-ft of torque, providing an outstanding combination of performance, fuel economy,^[3] exhaust emissions control, quietness and durability.

MULTI-DISPLACEMENT SYSTEM (MDS). It brings fuel economy to HEMI power. MDS allows the 5.7-liter HEMI VVT V8 engine with MDS—sporting best-in-class^[1] 368 horsepower and 391 lb-ft of torque — to operate with the fuel efficiency of only four cylinders as needed, for improved fuel economy.^[2] The HEMI engine is a marvel of modern engineering, thanks to its electronic throttle control and the advanced electronics that allow the HEMI cylinder deactivation system to switch from eight cylinders to four in 40 milliseconds (0.04 seconds)! The engine idles on eight cylinders for maximum smoothness, uses all eight for acceleration and heavy loads, and seamlessly transitions to four cylinders based on torque requirements, even at interstate highway speeds. Thanks to an MDS software upgrade, the 5.7-liter VVT HEMI now spends more time in fuel-saver mode. ^[1] Based on 2008 *Ward's* segmentation with 5.7L HEMI VVT V8. ^[2] 16 city, 25 highway, EPA est mpg with MDS. ^[3] 18 city, 26 highway EPA est mpg.

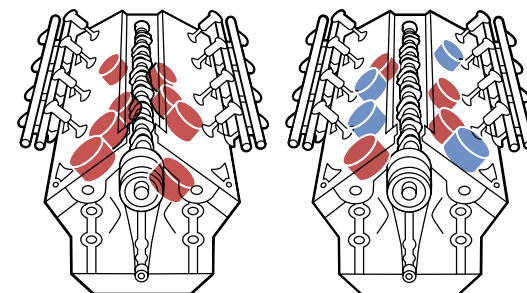

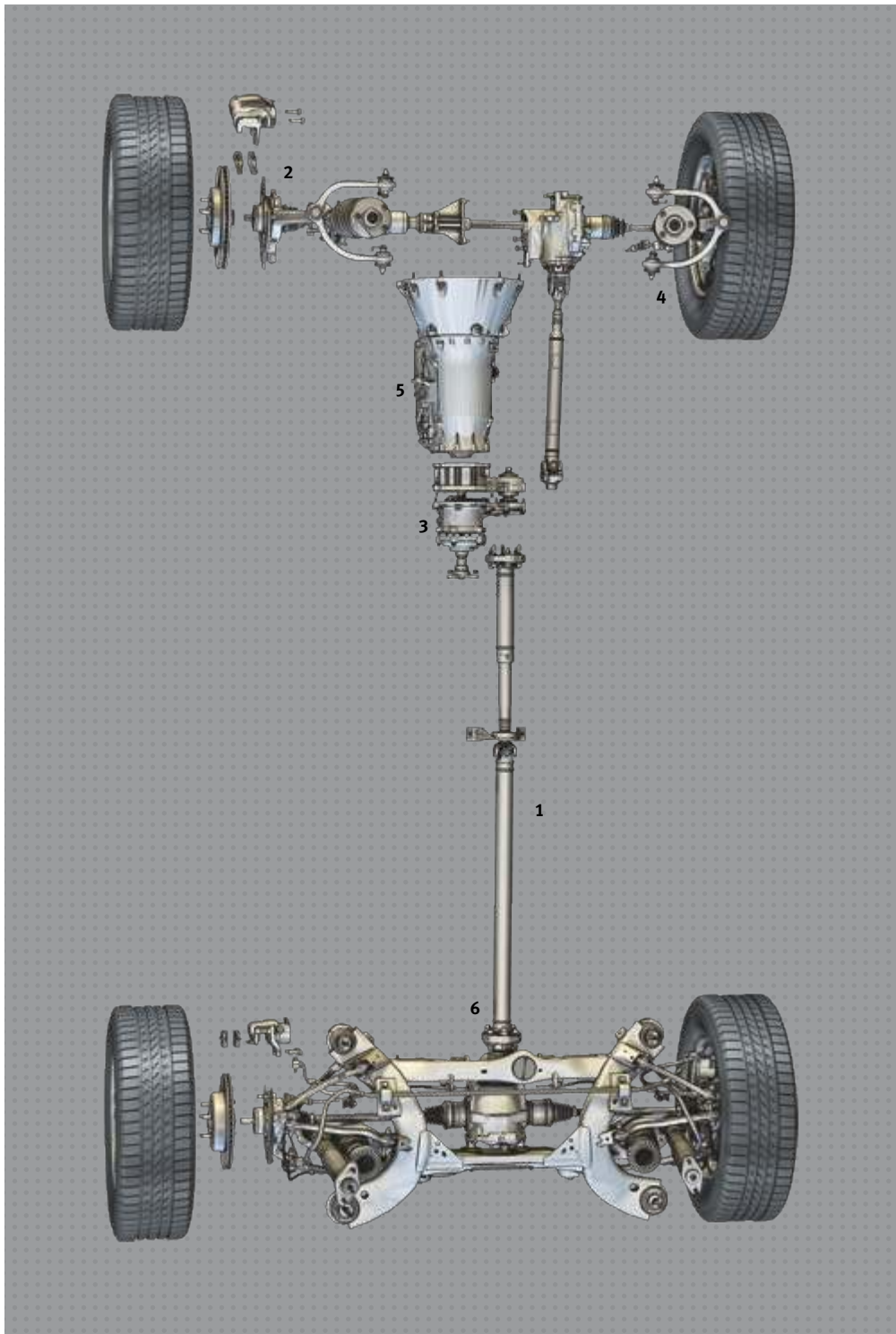

ENGINEERED ALONG THE CUTTING EDGE

The heart and soul of Charger is the powertrain. The driveline components of this state-of-the-art road warrior is the product of sophisticated computer-aided engineering and the most rigorous testing. By operating with precision at incredible speeds and able to withstand the rigors of the roughest road, these parts enable Charger to smoothly transfer engine energy to the wheels for a quality ride.

1 DRIVESHAFT. To ensure quiet operation, driveshaft alignment is maintained within one degree under all operating conditions, with a unique collapsing feature for enhanced passenger protection.

2 TWIN-PISTON CALIPERS. Front twin-piston aluminum calipers for Charger R/T provide a larger effective radius than single-piston calipers, for improved antilock brake system (ABS) response and maximum stopping power when Brake Assist is needed.

3 ALL-WHEEL DRIVE (AWD) WITH AUTOMATIC DISCONNECT. This exclusive feature on every Charger with AWD supplies power to both axles, delivering excellent balance for improved control under difficult road conditions. The system seamlessly transitions between rear-wheel drive and all-wheel drive with no driver intervention. When all-wheel drive is not required, the system automatically disconnects the front axle and opens the transfer case from the drivetrain to reduce friction and rotational mass. The system provides optimal traction, performance, and an improvement in fuel economy. Only Chrysler LLC offers these two independent technologies together.

4 INDEPENDENT SLA SUSPENSION. This four-wheel independent suspension is one of the most sophisticated and capable suspension systems the Chrysler Group has ever developed, designed to provide excellent handling, a smooth ride and, with the tires kept perpendicular to the road during cornering, a “glued-to-the-road” feel. Short/long arm (SLA) front and independent five-link rear suspension not only absorbs the bumps but provides added precision and responsiveness.

5 5-SPEED AUTOSTICK® TRANSMISSION. This available specially calibrated 5-speed AutoStick transmission offers fully automatic or clutchless manual shifting range selection and provides for more precise control of the gear ratio. Its true 5-speed gear range provides a better balance of performance and fuel efficiency. Torque management is electronically controlled by the 5-speed AutoStick transmission, making for smoother gear shifting, up or down. Standard on R/T, SRT8® and on all Charger models with AWD.

6 REAR DIFFERENTIAL. The rear differential is engineered with unique gear ratios and added case ribbings to improve cooling. This rear differential uses a synthetic lubricant that not only performs better at high temperatures for flow but is made to last in normal service for the life of the vehicle.

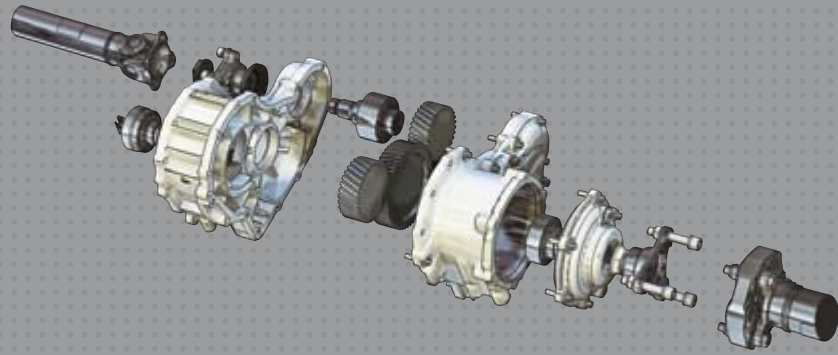

3 ALL-WHEEL DRIVE (AWD) WITH AUTOMATIC DISCONNECT

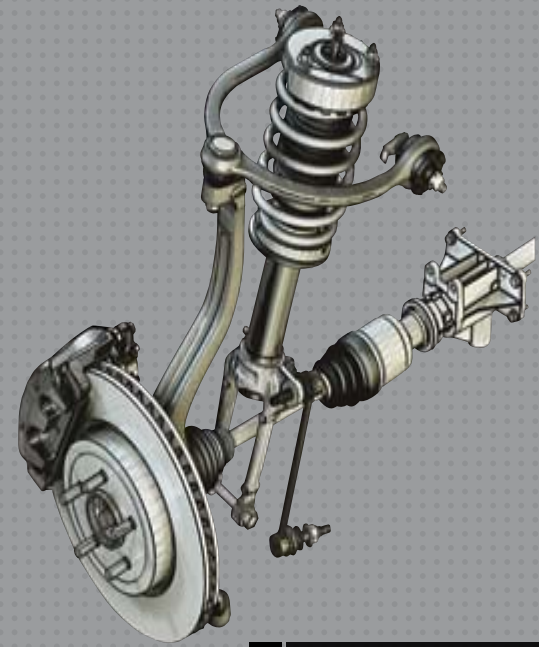

4 INDEPENDENT SUSPENSION

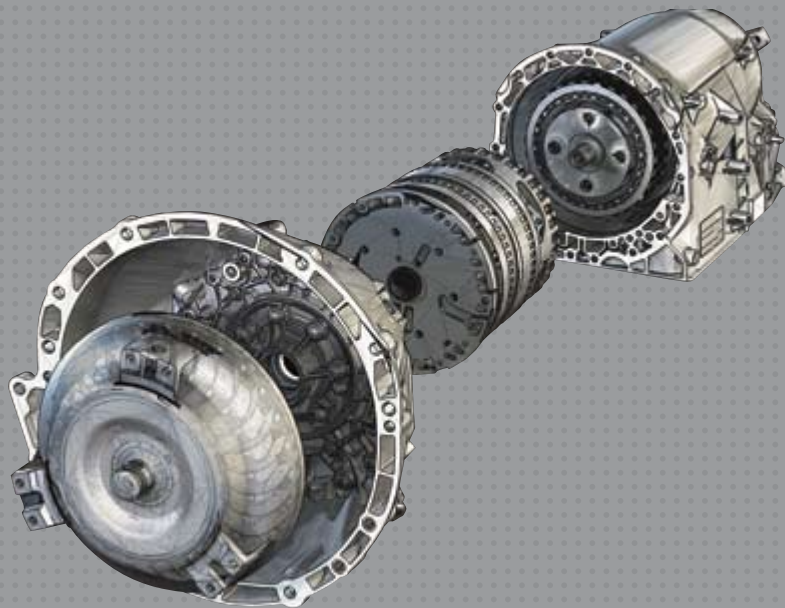

5 5-SPEED AUTOSTICK® TRANSMISSION

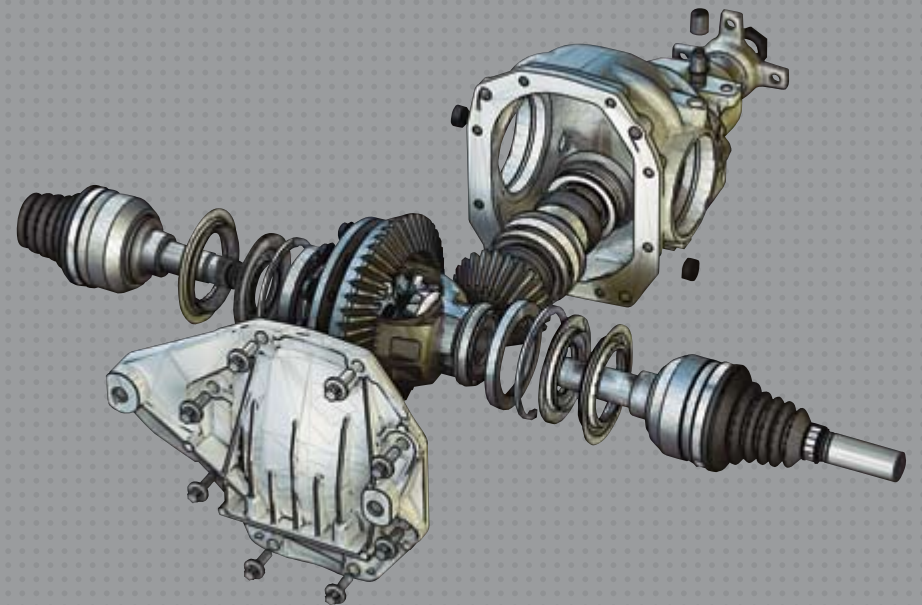

6 REAR DIFFERENTIAL



Charger R/T interior in Dark Slate Gray.



R/T INTERIOR

INTERIOR ACCENTS. The Charger interior features bright chrome and Satin Silver highlights throughout the sophisticated cockpit.

WHITEFACE GAUGES WITH UNIQUE BLUE/GREEN LIGHTING. Deep-tunneled Viper-inspired gauges with available silver rings warm the cockpit at night with a blue/green glow.

AVAILABLE STEERING WHEEL-MOUNTED AUDIO CONTROLS. Control song selection, radio tuning and volume, while keeping your hands where they should be when driving.

AVAILABLE EIGHT-WAY POWER-ADJUSTABLE DRIVER AND FRONT-PASSENGER SEATS. Fine-tune your seat to your liking.

SOFT, PADDED MATERIAL ADDED TO ARMRESTS AND CENTER CONSOLE. Durable padding adds comfort with upscale French seams.

ILLUMINATED MAP POCKETS AND FRONT CUP HOLDERS. Available LED lighting helps avoid late-night spills.

AVAILABLE HEATED DRIVER AND FRONT-PASSENGER SEATS. This feature is a must-have on cold mornings.

AVAILABLE 60/40 SPLIT-FOLDING REAR SEATS. The rear seats welcome combined loads. You can lower the second row completely for long or bulky items.

SRT® BOLSTERED SEAT. Exclusive SRT leather-trimmed, microfiber suede-accented performance seats have bolstered sides to keep driver and passenger firmly planted when cornering. For more cabin comforts, log on to dodge.com/charger



1 | iPod® ADAPTER



2 | REAR DVD (VES®)

1 INTERFACE MODULE FOR iPod® This FM-bounded adapter on **uconnect tunes** and **uconnect gps** allows you to play your music through your iPod® Click Wheel and listen through the vehicle's speakers. Available as an Authentic Dodge Accessory by Mopar. **2 REAR DVD VIDEO ENTERTAINMENT SYSTEM (VES®)**. This available high-end entertainment option gives you inputs for audio, video and games. **BOSTON ACOUSTICS® SOUND SYSTEM**. Crank the high-quality audio from the available Boston Acoustics Sound System with eight speakers and 368-watt amplifier Dolby Prologic II System with Surround Sound. For more on Charger's high-tech interior, visit dodge.com/charger



uconnect The available 6.5-inch touch-screen **uconnect tunes** provides entertainment, information, and communication, all through an AM/FM/CD/DVD⁽¹⁾ stereo system. A 30GB hard drive allows you to store photos, playlists, and songs, as well as rip, stash, organize, and shuffle up to 6,700 digital music files from CDs, integrated USB port, or exterior input jack. The touch-screen allows you to easily change radio stations and play digital audio files. **uconnect gps** includes all the same great features and adds the convenience of full mapping, turn-by-turn navigation with real-time traffic updates using **SIRIUS® Satellite Radio**. The included **uconnect phone** provides virtually hands-free, voice-activation capability with your Bluetooth® compatible phone.

uconnect studios Like a menu offering the best of in-vehicle technology, uconnect studios lets you either bundle or select individual available features, such as **SIRIUS SATELLITE RADIO**. Gain access to over 130 channels, including 100% commercial-free music, sports, news, talk, entertainment, traffic, and weather. Comes bundled with uconnect gps or can be added as a stand-alone feature. The available **SIRIUS BACKSEAT TV™** allows live content from three favorite family channels — Nickelodeon™, Disney Channel, and Cartoon Network — to stream directly to your Charger. For added value, front-seat passengers can enjoy separate programming on SIRIUS Satellite Radio while rear-seat occupants view SIRIUS Backseat TV.

uconnect phone Go high-tech with uconnect phone, an in-vehicle, voice-activated communication system that allows you to talk on your Bluetooth® compatible phone virtually hands-free. Comes bundled with uconnect gps or can be added as a stand-alone feature.

uconnect web Turn your Charger into a WiFi Hotspot with this Authentic Dodge Accessory by Mopar. Subscription required, sold separately. ⁽¹⁾uconnect in-dash DVD capability is not available in all states.

See your dealer for details.

AUTHENTIC DODGE ACCESSORIES



THE 2009 DODGE CHARGER INCLUDES THE BEST-IN-THE-BUSINESS LIFETIME POWERTRAIN LIMITED WARRANTY WITH UNLIMITED MILEAGE.

Non-transferable. See dealer for a copy of limited warranty and details.

Charger R/T Road/Track Performance Group in Bright Silver Metallic.

A PROFILE IN MODERN MUSCLE. Uncompromising power is a given driving Charger R/T with Road/Track Performance Group — its 5.7-liter VVT HEMI® V8 with MDS pumps out 372 horsepower and 398 lb-ft of torque. Its refined handling dynamics feature dampened, high-response steering and performance rear shocks. Charger R/T with Road/Track Performance Group adds a front chin spoiler, rear trunk lid spoiler, heritage “R/T” badging and 20-inch chrome-clad wheels.

AUTHENTIC DODGE ACCESSORIES BY MOPAR. When you enhance your Charger with Authentic Dodge Accessories by Mopar, you gain far more than substantial style, premium protection, powerful performance or extreme entertainment. You also benefit from the authentic difference found only in an original equipment accessory. It’s a difference you’ll recognize in the higher standards and tighter tolerances required of original equipment accessories. And one you’ll appreciate in our stricter testing measures, from impact performance tests to harsh on- and off-road durability testing.

MOLDED SPLASH GUARDS. They help protect your Charger from damage caused by gravel, salt and road debris, while adding some straight-on good looks.

REAR FASCIA AIR DIFFUSER. Add an aggressive and distinctive look to the rear fascia of your Charger with this paintable diffuser that includes simulated hexagon grille inserts.

Choose the full line of accessories that feature a fit, finish, and functionality designed specifically for your Charger. Check us out at mopar.com



ATTITUDE RUNS IN THE FAMILY. With a 3.5-liter SOHC High Output 24-valve V6 engine mated to a 4-speed automatic on rear-wheel drive and a 5-speed AutoStick® transmission with all-wheel drive (AWD), Charger SXT has what it takes to put 250 horsepower and 250 lb-ft of torque to use — a high level of standard performance features. To ensure a confident ride, SXT utilizes an antilock brake system (ABS), all-speed traction control and Electronic Stability Program (ESP)^[1] with Brake Assist and available all-wheel drive for improved control in difficult conditions. On the exterior, it delivers cool authority with its aggressive grille, bulging haunches, fastback roof line, and 17-inch aluminum wheels. Inside, it delivers versatility with a split-fold rear seatback and total comfort with low-back front bucket seats, air conditioning, and a power driver's seat. ^[1]No system, no matter how sophisticated, can repeal the laws of physics or overcome careless driving actions. Performance is limited by available traction, which snow, ice and other conditions can affect. When the ESP warning lamp flashes, the driver needs to use less throttle and adapt speed and driving behavior to prevailing road conditions. Always drive carefully, consistent with conditions. Always wear your seat belt.



A DEEP COMMITMENT TO SAFETY AND SECURITY

1 ADVANCED MULTISTAGE FRONT AIR BAGS. Advanced multistage front air bags deploy in staged amounts, depending on impact severity. Available supplemental front-seat-mounted side air bags^[1] help provide even better protection, while available front and rear supplemental side-curtain air bags^[1] help protect front and rear outboard occupants.

2 CRUSH ZONES. No one wants to test a vehicle's impact resistance, but Charger is ready if it occurs. The front structure is composed of crush zones: the area in front of the engine; the engine, transmission, and driveshaft; and the area between the engine and the instrument panel. Together, if these zones crush, they are designed to absorb impact energy and direct it away from the passenger compartment.

3 ANTILOCK BRAKE SYSTEM (ABS). Sometimes safety means being able to steer your car away from trouble — that's why Charger features available 4-wheel disc brakes with an antilock brake system. Besides affording premium stopping power, it enhances mobility and directional stability by allowing the driver to steer the vehicle while braking.

4 ELECTRONIC STABILITY PROGRAM (ESP)!^[2] In adverse conditions, the available Electronic Stability Program with Brake Assist works with an advanced all-speed traction control system to help the driver to maintain vehicle directional stability and it limits oversteering or understeering. Brake Assist detects conditions when maximum force is needed for optimum stopping power. For more safety and security enhancements, visit dodge.com/charger ^[1]Always sit properly in the seat with the seat belt fastened. Children 12 and under should always be in a backseat correctly using an infant or child restraint system or the seat belt positioned correctly for the child's age and weight. ^[2]No system, no matter how sophisticated, can repeal the laws of physics or overcome careless driving actions. Performance is limited by available traction, which snow, ice and other conditions can affect. When the ESP warning lamp flashes, the driver needs to use less throttle and adapt speed and driving behavior to prevailing road conditions. Always drive carefully, consistent with conditions. Always wear your seat belt.



CHARGER R/T DAYTONA^[1]
STONE WHITE

CHARGER SE
BRILLIANT BLACK CRYSTAL PEARL

CHARGER R/T
DARK TITANIUM METALLIC

CHARGER SXT
LIGHT SANDSTONE METALLIC

CHARGER SRT8[®]
DEEP WATER BLUE PEARL

CHARGER SRT8[®] SUPER BEE
HEMI ORANGE PEARL

CHARGER SRT8[®] Includes the 6.1-liter SRT[®] HEMI[®] V8 engine with Hemi Orange engine block, leather-trimmed seats with studs- pattern suede microfiber seat inserts, Brembo[®] Performance four-piston brake calipers, SRT unique calibration ESP, performance-tuned steering, leather-wrapped steering wheel with carbon fiber upper trim, high-performance lowered suspension, functional hood scoop, and 20-inch SRT forged-aluminum wheels with high-performance tires.

CHARGER R/T DAYTONA^[1] Includes the 5.7-liter VVT HEMI V8 with MDS engine with 372 horsepower, Hemi Orange-accented engine cover and intake, dual exhaust, high-response steering, performance suspension, eight-way power driver and front-passenger seats with embroidered “Daytona” logo. “Hemi” and “Daytona” blackout decals, classic R/T, honeycomb blackout grille insert, 20-inch chrome-clad wheels, black front chin and rear trunk lid spoilers, remote start, Mopar air diffuser, supplemental front-seat-mounted side air bags^[2] and supplemental side-curtain air bags^[2]

CHARGER R/T Includes the 5.7-liter VVT HEMI V8 with MDS engine with 368 horsepower and 391 lb-ft of torque, 5-speed AutoStick[®] transmission, ABS, ESP with all-speed traction control and Brake Assist, 18-inch ultra-brite aluminum wheels and sporty bright dual exhaust tips, heated leather-trimmed seats, automatic dual zone temperature control, power heated exterior mirrors, and much more.

CHARGER SXT Includes 3.5-liter V6 engine, fog lamps, heated exterior mirrors, air filtration and power adjustable pedals, 17-inch machined aluminum wheels, 60/40 split-folding rear seatback with center armrest, eight-way power-adjustable driver’s seat, six Boston Acoustics[®] speakers with 276-watt DSP amplifier, chrome grille surroundings, SIRIUS[®] Satellite Radio, ESP with Brake Assist and all-speed traction control, and more.

CHARGER SE Includes AM/FM radio with CD player, auxiliary input jack and four speakers, accessory delay, driver and passenger manual lumbar support, enhanced battery saver, outside temperature display, power mirrors, power trunk lid release, power windows and locks, speed control, Sentry Key[®] anti-theft engine immobilizer, advanced multistage driver and front passenger air bags^[2] and Tire Pressure Monitoring System.

CHARGER SRT8[®] SUPER BEE Includes the 6.1-liter SRT HEMI V8 with 425 horsepower and 420 lb-ft of torque, 20-inch ultra-brite forged aluminum wheels with anodized matte black pockets, monochromatic crosshair grille with honeycomb detail, body-color fascias, HEMI decals, performance display in cluster, HEMI Orange Pearl exterior paint, Super Bee logo on cluster display, and more.

CHARGER R/T WITH ROAD/TRACK PERFORMANCE GROUP R/T Road/Track includes the 5.7-liter VVT HEMI V8 with MDS producing 372 horsepower; 5-speed AutoStick; performance heavy-duty 4-wheel disc ABS with vented front and rear discs; electronic speed control with steering column-mounted controls; performance rack-and-pinion steering; performance independent front and rear suspension; dual exhaust with bright tips; power body-color, folding, heated mirrors; trunk lid body-color spoiler; front chin spoiler; 20-inch aluminum chrome-clad wheels; supplemental front-seat-mounted side air bags^[2] and supplemental side-curtain air bags^[2] For all the outstanding features on Charger models, please see the Standard/Optional chart. ^[1]Late availability. ^[2]Always sit properly in the seat with the seat belt fastened.



CHARGER FABRICS

EXTERIOR COLOR	SRT8	ROAD/TRACK PERFORMANCE GROUP	DAYTONA	R/T	SXT ^[1]	SE
Bright Silver Metallic	D	C		B, F	A, E, B, F	A, E
Brilliant Black Crystal Pearl	D	C		B, F	A, E, B, F	A, E
Dark Titanium Metallic				F	E, F	E
Deep Water Blue Pearl	D	C		B, F	A, E, B, F	A, E
Hemi Orange Pearl ^[2]	D		C			
Inferno Red Crystal Pearl				B, F	A, E, B, F	A, E
Light Sandstone Metallic				F	E, F	E
Stone White		C		B, F	A, E, B, F	A, E
TorRed	D	C		B, F	A, E, B, F	A, E

^[1]Leather-trimmed seats are optional on SXT. ^[2]SRT8 Super Bee exclusive color.



CHARGER WHEELS

- 17-inch machined aluminum wheel (standard on SE and SXT RWD)
- 18-inch ultra-brite machined aluminum wheel (available on SXT, standard on R/T RWD)
- 18-inch chrome-clad aluminum wheel (available on SXT and R/T RWD)
- 18-inch machined-face aluminum wheel (standard on AWD)
- 20-inch chrome-clad aluminum wheel (standard on Daytona and R/T with Road/Track Performance)
- 20-inch SRT[®] forged, polished aluminum (standard on SRT8)
- 20-inch ultra-bright SRT forged, fully polished aluminum with anodized matte black pockets (standard on SRT8 Super Bee)
- 20-inch polished aluminum wheel (optional on SRT8)
- 18-inch 5-spoke machined-bright face, black-pocket cast aluminum (Authentic Dodge Accessory)



CHARGER BUYER'S GUIDE

FEATURES COMMON ACROSS ALL TRIM LEVELS

AIR BAGS ^[1] — Advanced multistage driver and front-passenger
AIR FILTRATION — Particulate air filter
ANTENNA — Located in back glass
ASHTRAY — Front
BATTERY — 625 amp, maintenance free
BATTERY-SAVER FEATURE — Enhanced, programmable to turn headlamps and other switched and non-switched interior lamps off after ignition is turned off
CHILD SEAT ANCHOR SYSTEM (LATCH) — Mounts for three child seats in the second row help ease the installation of compatible aftermarket child seats
CLADDING — Lower bodyside accent
CONSOLE — Floor, with illuminated cup holders, coin holder, CD and cell phone storage with 12V power outlet, and rear seat heat and A/C outlets
DEFROSTER — Rear window
DOOR HANDLES — Body-color, handle-style
DOOR LOCKS — Power, speed-sensitive — Rear doors child protection
EMERGENCY DECK LID RELEASE
FLOOR COVERING — Carpet
FLOOR MATS — Premium front and rear (CLZ)
GLASS — Solar Control, all windows
HEADLAMPS — Black bezel halogen with delay
HORN — Electric Dual Note
LIGHTING — Dual front map, glove box and rear reading with theater-dimming — Rear reading/courtesy — Trunk/liftgate flood lamp
MIRRORS, INTERIOR — Rearview, day/night
PASSENGER ASSIST HANDLES
POWER ACCESSORY — 12V Power outlet located in center console
REMOTE KEYLESS/ILLUMINATED ENTRY SYSTEM — Includes two transmitters
SEAT BELTS — Height-adjustable 3-point driver and front-passenger with traveling buckles and seat belt pretensioners; 3-point lap/shoulder belts at all rear-seat positions
SENTRY KEY® — Antitheft engine immobilizer
SPEED CONTROL — Electronic with steering column-mounted controls
STEERING COLUMN — Tilt/telescoping, manual
TIP START SYSTEM
TRUNK LID RELEASE — Power
MANUAL DRIVER/PASSENGER ADJUSTABLE LUMBAR
WIPERS — Variable Intermittent

• = Included. P = Available within package noted. O = Optional.

^[1] Always sit properly in the seat with the seat belt fastened. Children 12 and under should always be in a backseat correctly using an infant or child restraint system or the seat belt positioned correctly for the child's age and weight. ^[2] uconnect in-dash DVD capability not available in all states. See your dealer for details. ^[3] No system, no matter how sophisticated, can repeal the laws of physics or overcome careless driving actions. Performance is limited by available traction, which snow, ice and other conditions can affect. When the ESP warning lamp flashes, the driver needs to use less throttle and adapt speed and driving behavior to prevailing road conditions. Always drive carefully, consistent with conditions. Always wear your seat belt.



ENGINE AND TRANSMISSION

	SE	SXT	R/T	R/T Road/Track	Daytona	SRT8
2.7L DOHC 24V V6/4-SPEED AUTOMATIC	23C					
3.5L SOHC HIGH OUTPUT 24V V6/4-SPEED AUTOMATIC		26G 26H				
3.5L SOHC HIGH OUTPUT 24V V6/5-SPEED AUTOSTICK®		27G 27H				
5.7L VVT WITH MDS V8/5-SPEED AUTOSTICK®			29N 29P	29R	29V	
6.1L SOHC SRT HEMI V8/5-SPEED AUTOSTICK®						21X

MECHANICAL

ACTIVE TRANSFER CASE WITH FRONT AXLE DISCONNECT (AWD models only)		•	•	•	•	
ALTERNATOR — 140-amp — 160-amp	•					
BRAKES — 4-wheel disc with vented front and solid rear discs — 4-wheel disc antilock with vented front and solid rear discs (included with ESP) — Performance 4-wheel disc antilock with vented front and rear discs — 4-wheel disc antilock with vented front and rear discs Heavy Duty — High-performance 4-wheel disc antilock with vented 14" front and 13.8" rear discs, includes Brembo® Performance 4-piston calipers (BR5)	•					
ENGINE COOLING — Standard Duty — Heavy Duty — Severe Duty (AWD models only) — Severe Duty II		•	•	•	•	•
ENGINE BLOCK HEATER	O	O	O	O	O	O
ENGINE CONTROLLER — High Speed					•	•
ENGINE COVER — Painted Hemi Orange						•
REMOTE START SYSTEM (Included in Popular Equipment Group)					P	•
SPEEDOMETER — 140 mph — 160 mph — 180 mph	•	•	•		•	•
STEERING — Power, rack and pinion — Performance — Performance-tuned	•	•	•	•	•	•
SUSPENSION — Independent front and rear — Touring independent front and rear — Performance independent front and load leveling rear with height control — High-performance lowered independent front and rear	•	•				•
EXTERIOR FEATURE						
DECAL — Daytona, decklid blackout and HEMI on hood						•
DIFFUSER — Mopar, rear air						•
EXHAUST SYSTEM — Stainless steel — Performance dual exhaust with bright tips	•	•	•		•	•
FUEL TANKS — 18 gallon with tethered cap — 19 gallon with tethered cap	•	•	•		•	•
GRILLE — Black with body-color surround — Black with bright surround — Black Honeycomb with black surround — Black Honeycomb with body-color surround	•					•

EXTERIOR FEATURES (CONTINUED)

	SE	SXT	R/T	R/T Road/Track	Daytona	SRT8
HEADLAMPS — Black bezel Xenon High Intensity Discharge with delay (AWD ON 29N) — Automatic — Fog lamps			O	O	O	O
HOOD — Functional scoop						•
MIRRORS, EXTERIOR — Power fixed, black — Power fixed, black, heated — Power fold away, body-color, heated	•	•			•	•
MOLDING — Bodyside body-color (included in Protection Group) (Std on AWD)	O	P/•	P/•	P/•	•	
MOONROOF — Power, with one touch open/close feature		O	O	O	O	O
SPOILER — Front fascia — Rear trunk lid black — Rear trunk lid body-color					•	•
TIRES — P215/65R17 BSW All-Season Touring — P225/60R18 BSW All-Season Touring (Std on AWD) — P225/60R18 All-Season Touring self-sealing (included in Protection Group) (AWD on 27G) — P245/45ZR20 All-Season Performance — P245/45ZR20 and 255/45ZR20 Performance — Compact Spare Tire	•	•			•	•
TIRE SERVICE KIT						•
WINDOWS — Power with driver's one-touch auto-up/down, and antipinch feature — Power with driver's and front-passenger one-touch auto-up/down, and antipinch feature	•	•			•	•
INTERIOR FEATURES						
ADJUSTABLE PEDALS — Power		•	•	•	•	•
AIR CONDITIONING — Manual Temperature Control — Automatic Dual Zone Temperature Control	•	•			•	•
BADGE — Numbered (included in Super Bee Special Edition Group)						P
CARGO NET		•	•	•	•	•
DOOR LOCKS — Satin silver lock knobs					•	•
ELECTROLUMINESCENT CLUSTER (AWD models only)	•	•				
ELECTRONIC VEHICLE INFORMATION CENTER (EVIC) — Reconfigurable driver-interactive information display with steering wheel-mounted controls				•	•	•
HOMELINK® UNIVERSAL TRANSCIEVER — Programmable, 3-function remote for garage door, home lighting or security devices				•	•	•
INTERIOR ACCENTS — Silver trim includes, interior door pull handles, instrument panel and shift knob — Graphite patterns	•	•	•	•	•	•
INSTRUMENT CLUSTER — Reconfigurable with 0-60 time, ¼ mile time and speed, friction circle and drift angle display (included with Super Bee Special Edition)						P
MIRRORS, INTERIOR — Rearview, auto dimming with microphone (included in Protection Group and with uconnect phone and uconnect gps) — Visor Vanity, passenger side	P	P	P	P	P	P

INTERIOR FEATURES (CONTINUED)	SE	SXT	R/T	R/T Road/Track	Daytona	SRT8
MIRRORS, INTERIOR (continued) — Visor vanity illuminated driver and passenger side			•	•	•	•
PERFORMANCE DISPLAY — Includes Digital Speedometer, 1/4 and 1/4 mile time and speed, braking distance, 0-60 mph time and G-forces meter longitudinal and lateral (included in SRT Option Group II)						P
SHIFT KNOB — Urethane with chrome accent — Leather wrapped	•	•				
SPEEDOMETER — 140 mph — 160 mph — 180 mph	•	•	•	•	•	•
STEERING WHEEL — Urethane — Leather-wrapped — Steering wheel-mounted audio and EVIC controls (included in uconnect tunes and gps)	•	•				
TEMPERATURE DISPLAY — Outside, with compass, located in EVIC			•	•	•	•
TRAVELER/MINI TRIP COMPUTER			•	•	•	•
ENTERTAINMENT						
RADIOS— AM/FM stereo radio with single-disc CD player, changer controls and auxiliary audio input jack (RES) — AM/FM stereo radio with integrated 6-disc CD/DVD player with MP3 capability (REQ) (included in Popular Equipment Group and SRT8 Option Group II)	•	•	•	•	•	•
uconnect — uconnect tunes ²¹ — Includes AM/FM/CD/DVD/30GB Hard Drive/MP3 radio with touch-screen operation (included in Super Bee Special Edition Group) — uconnect gps ²¹ — Includes AM/FM/CD/DVD/30GB HDD/MP3 with Navigation and touch-screen/voice recognition operation and real-time traffic alerts (included in SRT Option Group III) — uconnect studios — With SIRIUS Backseat TV, TM includes one-year subscription by SIRIUS. Requires rear seat Video Entertainment System (VES [®]) (included in SRT Option Group III) — uconnect studios — With SIRIUS [®] Satellite Radio. Includes one-year subscription by SIRIUS		O	O	O	O	O/P
SOUND SYSTEMS — 4 Speakers — 6 Boston Acoustics [®] speakers with 276-watt digital amplifier — 7 Boston Acoustics [®] speakers with 368-watt digital amplifier and subwoofer and Matrix Surround System (included in Popular Equipment Group) — 13 SRT [®] High-Performance KICKER [®] speakers (8 locations) with a 322-watt digital amplifier and 200-watt subwoofer amplifier (included with SRT Option Group II)	•	•				
REAR SEAT VIDEO ENTERTAINMENT SYSTEM (VES [®]) — Includes remote control and wireless headphones			O	O	O	O

SEATING AND TRIM

SEATING AND TRIM	SE	SXT	R/T	R/T Road/Track	Daytona	SRT8
SEATS, FRONT — Cloth-trimmed — Leather-trimmed — Performance seats with Perforated Preferred Suede — Performance seats with leather-trim and Studs pattern embossed suede — Manual adjustable driver and passenger seat — 8-way power driver's seat — 8-way power driver's and front passenger seat — Heated front seats	•	•				
REAR — 60/40 split-folding rear bench — Rear bench center armrest with cup holders		•	•	•	•	•
SAFETY AND SECURITY						
AIR BAGS ²¹ — Side-curtain for front and rear outboard occupants (included in Protection Group and Supplemental Side Air Bags) — Supplemental side air bags includes supplemental front seats side air bags and side-curtain for front and rear outboard occupants (included in Protection Group)	P	P	P	P	•	O
ELECTRONIC STABILITY PROGRAM ²¹ — Includes Brake Assist and all-speed traction control	O	•	•	•	•	•
SECURITY ALARM (included in Popular Equipment Group and SRT Option Group II)				•	P	P
SRT TRACK EXPERIENCE				•	P	•
TIRE PRESSURE MONITORING DISPLAY (included in Popular Equipment Group)				•	P	•
PACKAGES						
POPULAR EQUIPMENT GROUP — Includes Security Alarm, 7 Boston Acoustics speakers with 368-watt digital amplifier and subwoofer, AM/FM stereo radio with integrated 6-disc CD/DVD player with MP3 capability, Remote Start System						O
PROTECTION GROUP — Includes body-side body-color narrow molding, front and rear supplemental side-curtain air bags, Supplemental front-seat side air bags, uconnect phone, self-sealing tires, auto-dimming rearview mirror with microphone		O	O	O	O	
SRT OPTION GROUP II — Includes Performance display, Security Alarm, 13 SRT High-Performance KICKER [®] speakers (8 locations) with a 322-watt digital amplifier and 200-watt subwoofer amplifier, AM/FM stereo radio with integrated 6-disc CD/DVD player with MP3 capability (upgrade to uconnect gps with Navigation for an additional charge)						O
SRT OPTION GROUP III — uconnect gps with real-time traffic, uconnect studios with SIRIUS Satellite Radio, uconnect phone auto-dimming rearview mirror with microphone						O
SUPER BEE SPECIAL EDITION GROUP — Includes reconfigurable display with 0-60 time, 1/4 mile time, 1/8 mile time, and friction circle, Super Bee badge, Deck lid blackout tape, 20" ultra-brite aluminum SRT wheels, uconnect tunes, serialized dash plaque						O

• = Included. P = Available within package noted. O = Optional.



The Dodge Charger includes a Lifetime Powertrain Limited Warranty. Non-Transferable. Not available on SRT[®] diesel vehicles, Sprinter, Ram Chassis Cab, and certain fleet vehicles. See dealer for a copy of limited warranty and details.

3/36 BASIC LIMITED WARRANTY

All Dodge vehicles are covered by the Chrysler 3-year/36,000-mile Basic Limited Warranty. See dealer for a copy of this limited warranty. Excludes normal maintenance and wear items.

Chrysler Financial delivers Chrysler, Jeep[®], and Dodge customers a personal, worry-free automotive financing experience. More than just another finance company with competitive rates, Chrysler Financial stands behind you through life's twists and turns by offering fast approvals, flexible terms and unparalleled personalized service. Visit cf.com or your Dodge dealer to discover all that Chrysler Financial offers. Taking care of you, all along the way.



The only insurance guaranteed to repair your vehicle using Authentic Dodge Collision Repair Parts by Mopar for as long as you own your Dodge vehicle, and up to \$100 off your deductible when those repairs are done at a Dodge dealership – all at rates that are tough to beat. For a free quote, visit dodgeautoinsurance.com or call 800-836-1598 and mention keycode QL9XXX.



Your Dodge is one of the best performing vehicles on the road. Why not protect your investment with a Chrysler Service Contract or Maintenance Plan? For more information, see your Dodge dealer, call 1-800-442-2666 or visit servicecontracts.chrysler.com.



Enhance your Dodge Charger with Authentic Dodge Accessories by Mopar. They're designed specifically for your vehicle for exceptional fit, finish and performance. Visit your dealership or mopar.com.



This suite of integrated digital systems bundles entertainment, information, and communication. For more information, visit your dealer.



SIRIUS Satellite Radio delivers over 130 channels, including 100% commercial-free music, sports, news, talk, entertainment, traffic and weather. Factory installed SIRIUS Satellite Radio includes a one-year subscription. For more information, go to SIRIUS.com.



SIRIUS Backseat TVTM features the best brands in family entertainment 24/7: Nickelodeon, Disney Channel and Cartoon Network Mobile – plus all your favorite SIRIUS Satellite Radio audio entertainment. It's perfect for families on the go. All three channels are directly broadcast to the SIRIUS tuner and sent to your backseat video monitor(s). For added flexibility, rear-seat passengers can enjoy SIRIUS Backseat TV while front-seat occupants listen to SIRIUS Satellite Radio. Enjoy car trips with the family and never again be asked, "Are we there yet?"



Earn 5 points per dollar charged at your Dodge dealership and 1 point per dollar everywhere Visa[®] is accepted. Whether you're saving points for your down payment or for your vehicle's scheduled maintenance, it pays to be a Dodge Rewards Visa cardholder. For more information or to apply, visit dodgecreditcard.com or call 800-478-6179.



About this catalog: Since the time of printing, some of the information you'll find in this catalog may have been updated. Ask your dealer for details. Some of the equipment shown or described throughout this catalog is available at extra cost. Specifications, descriptions, illustrative materials, and all competitive comparisons contained herein are as accurate as known at the time this publication was approved for printing. Chrysler LLC reserves the right to discontinue models at any time or change specifications without notice or without incurring obligation. All options are required in combination with other options. For the price of the model with the equipment you desire, or verification of specifications contained here, see your Dodge dealer. Dodge, HEMI, Mopar, Sentry Key, SRT, SRT8, uconnect, and VES are registered trademarks of Chrysler LLC. "SIRIUS," the SIRIUS dog logo "SIRIUS Backseat TV" and related marks are trademarks of SIRIUS Satellite Radio Inc. All other trademarks, service marks and logos are the property of their respective owners. All rights reserved. Subscription required. Prices and programming content are subject to change. Not available in Alaska and Hawaii. For full terms and conditions, visit SIRIUS.com. ©2008 Viacom International Inc. All rights reserved. Insurance is underwritten by member companies of American International Group, Inc. Bluetooth is a registered trademark of Bluetooth SIG Inc. Boston, Boston Acoustics, and the Boston logo are registered trademarks of Boston Acoustics, Inc. HomeLink is a registered trademark owned by Johnson Controls, Inc. The Dodge Rewards Visa credit card is issued by FIA Card Services, N.A. iPod and iPhone are registered trademarks of Apple Inc.